

July 1998

Minutes of a meeting on LHC Impedance
held on Friday 12 June 1998

Present: O. Brüning, H. Dijkstra, M. Ferro-Luzzi, G. von Holtey, J.-B. Jeanneret, J.-P. Koutchouk, D. Lacarrère, T. Ruf, F. Ruggiero (Chairman), R. Veness, S. Weisz

Agenda: 1) Beam properties and control around IP8
2) Wakefield calculations for the LHCb experimental beam pipe

Introduction

In view of various technical issues raised by LHCb collaborators from NIKHEF, related to the interfacing of the Vertex Detector with LHC, the first part of the meeting is devoted to a preliminary discussion of beam optics for IP8.

1 Beam properties and control around IP8

After some discussion, F. Ruggiero suggests to make a list of the main questions for the LHC optics team and see whether they can be answered immediately or require some further meeting. G. von Holtey summarizes the main questions concerning the Vertex Detector:

1. Is it possible for the Roman pots to approach the measured beam position down to 5 mm?
2. What happens if the beam moves?
3. What is a realistic range of values for β^* ?

As shown in Table 1, the answer of J.-B. Jeanneret to the first question is ‘yes’ provided the detector position can be adjusted in *both* horizontal and vertical directions.

1.1 Optics and separation for IP8

O. Brüning discusses constraints and optical solutions obtained for LHCb [1, 2]. The nominal collision optics at IP8 is $\beta^* = 14$ m, but LHCb envisages to utilise values of β^* in the range of 2 to 35 m. In order to avoid an interaction of the two beams during injection and ramp, the beams are separated in the common part of the interaction region by additional correctors. The separation scheme at IR8 foresees a vertical crossing-angle of $200 \mu\text{rad}$ in the vertical plane and a parallel separation of 2 mm in the horizontal plane. The orbit bump reduces the acceptance of the injection elements and the magnets next to the IP.

The injection and collision optics (version 5.0) are shown in Figs. 1 and 2, respectively, while the separation scheme is depicted in Fig. 3.

2 Wakefield calculations for the LHCb experimental beam pipe

M. Ferro-Luzzi presents an overview of the Vertex Detector design and of preliminary wakefield calculations performed by N. von Bakel using MAFIA.

A sketch of the 17 stations each consisting of two staggered silicon planes is shown in Fig. 4. The vacuum tank, shown in Fig. 5, is conical with a length of 177 cm, a radius of 55 cm at the upstream end and of 60 cm at the downstream end. The Vertex Detector stations are mounted, at the top and the bottom, on two cooled aluminium support frames attached to linear actuators, allowing retraction of the detectors by 3 cm from the beam axis during injection. To minimise tensions on the connecting beam pipe, a self-supporting (spherical) shape has been chosen for the exit window, consisting of an aluminium foil of 2 mm thickness and 1 m radius of curvature, with a heavy rectangular support that does not obstruct the 470 mrad corner-to-corner acceptance of the downstream tracking stations.

A $50 \div 100 \mu\text{m}$ Al foil separates the primary from the secondary vacuum, where detectors and front-end electronics will be located. This thin bellows-like structure provides partial RF-shielding of the detectors and has an undulation depth of $8 \div 9$ mm over the distance between each silicon plane. Answering a question by O. Brüning, M. Ferro-Luzzi explains that such a ‘Roman pot’ solution is preferable over that of a cone or tube, since it reduces the thickness of material crossing. In addition to bellows, a ‘wakefield

suppressor' consisting of four metal strips (5 μm thick stainless steel) will be mounted between the beam and the Vertex Detector to substantially reduce the RF-coupling due to the cavity-like structure of the detector encapsulation.

Preliminary MAFIA calculations have been performed by N. von Bakel for a cylindrical closed structure with 50 cm radius(?) and using about 600000 mesh points. The shunt impedances of the first few modes, with frequencies of 85, 97 and 120 MHz, ranges between 84 Ω and 1.5 M Ω and the estimated power deposition for a nominal beam current of 0.5 A is about 20 W. With four metallic strips (4 mm wide) the shunt impedances drop almost to zero.

References

- [1] O. Brüning, *Optics Solutions for the Combined Experimental and Injection Regions in the LHC*, CERN LHC Project Report 189 (June 1998).
- [2] O. Brüning and J.B. Jeanneret, *Optics constrains imposed by the injection in IR2 and IR8*, CERN LHC Project Note 141 (May 1998).
- [3] LHCb Collaboration, *LHCb Technical Proposal*, CERN/LHCC 98-4, LHCC/P4 (February 1998).

APERTURE AT THE IP OF LHCb
 - FOR DISCUSSION -

In collision, the inner radius of the vertex detector shall be large enough to leave space for n transverse beam units including tolerances, i.e.

$$r_{min} = \Delta_{co} + \Delta_{tol} + n\sigma \quad (1)$$

with $\sigma = (\varepsilon\beta^*)^{1/2}$, $\varepsilon = 5.0310^{-4}$ at 7 TeV. For the other parameters, I tentatively define

$$\Delta_{co} = 1 \text{ mm} \quad \Delta_{tol} = 2 \text{ mm} \quad (2)$$

$$n = 15 \quad (3)$$

$$\beta^* = 36 \text{ m} \quad \Leftrightarrow \quad \sigma = 0.14\text{mm} \quad (4)$$

This supposes (Δ_{tol}) a vertex detector which is adjustable in both the horizontal and the vertical direction. Needless to say, the detector must in addition be opened at injection, otherwise σ must be computed at injection (~ 4 times larger). The value of β^* is the maximum value which is affordable with the crossing angle needed, adding 20% for beta-beating.

The end result would then be

$$r_{min} = 1 + 2 + 2.1 = 5.1\text{mm} \quad (5)$$

Table 1: Considerations of J.-B. Jeanneret on the minimum possible distance of the Vertex Detector from the beam.

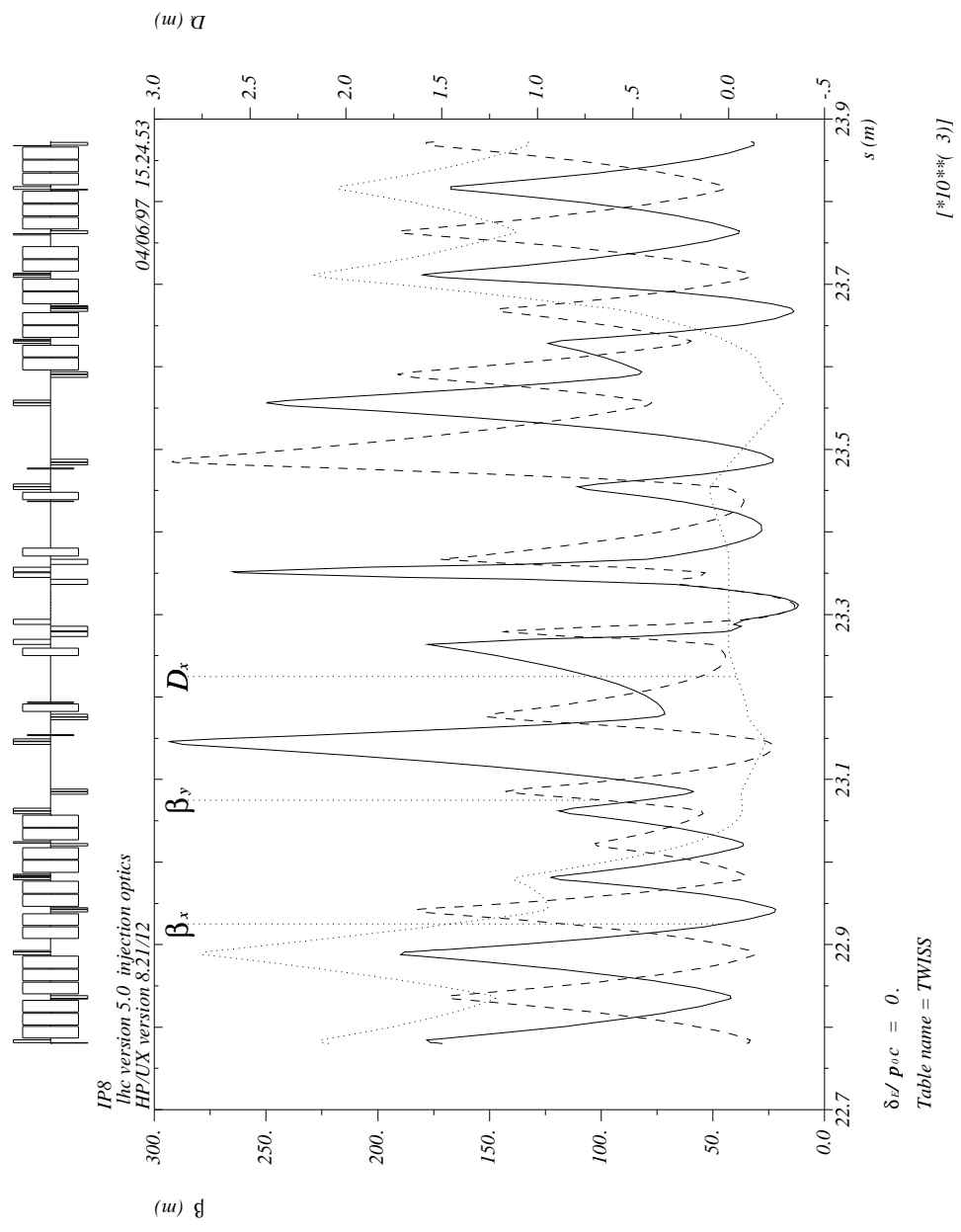

Figure 1: LHCb injection optics.

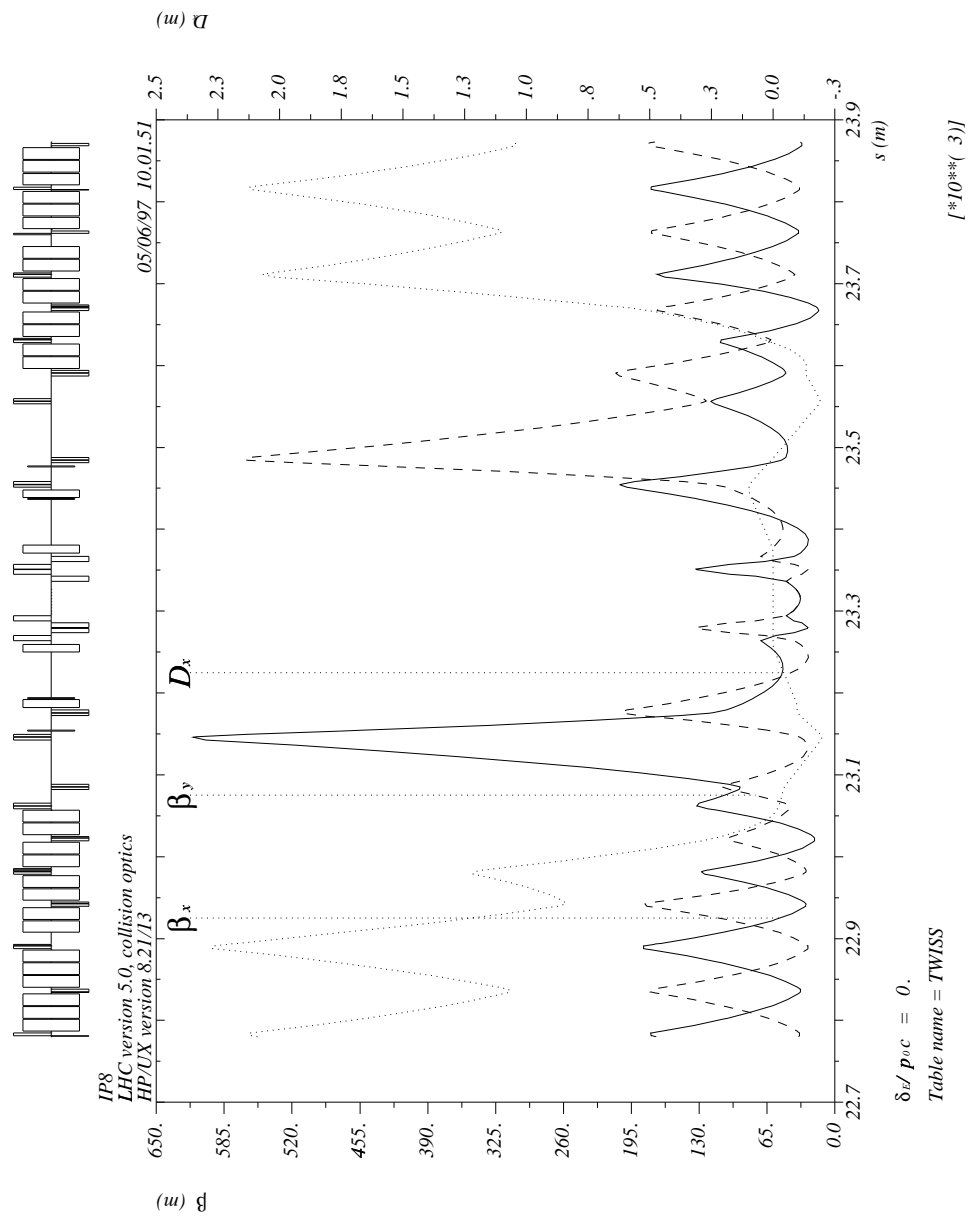

Figure 2: LHCb collision optics.

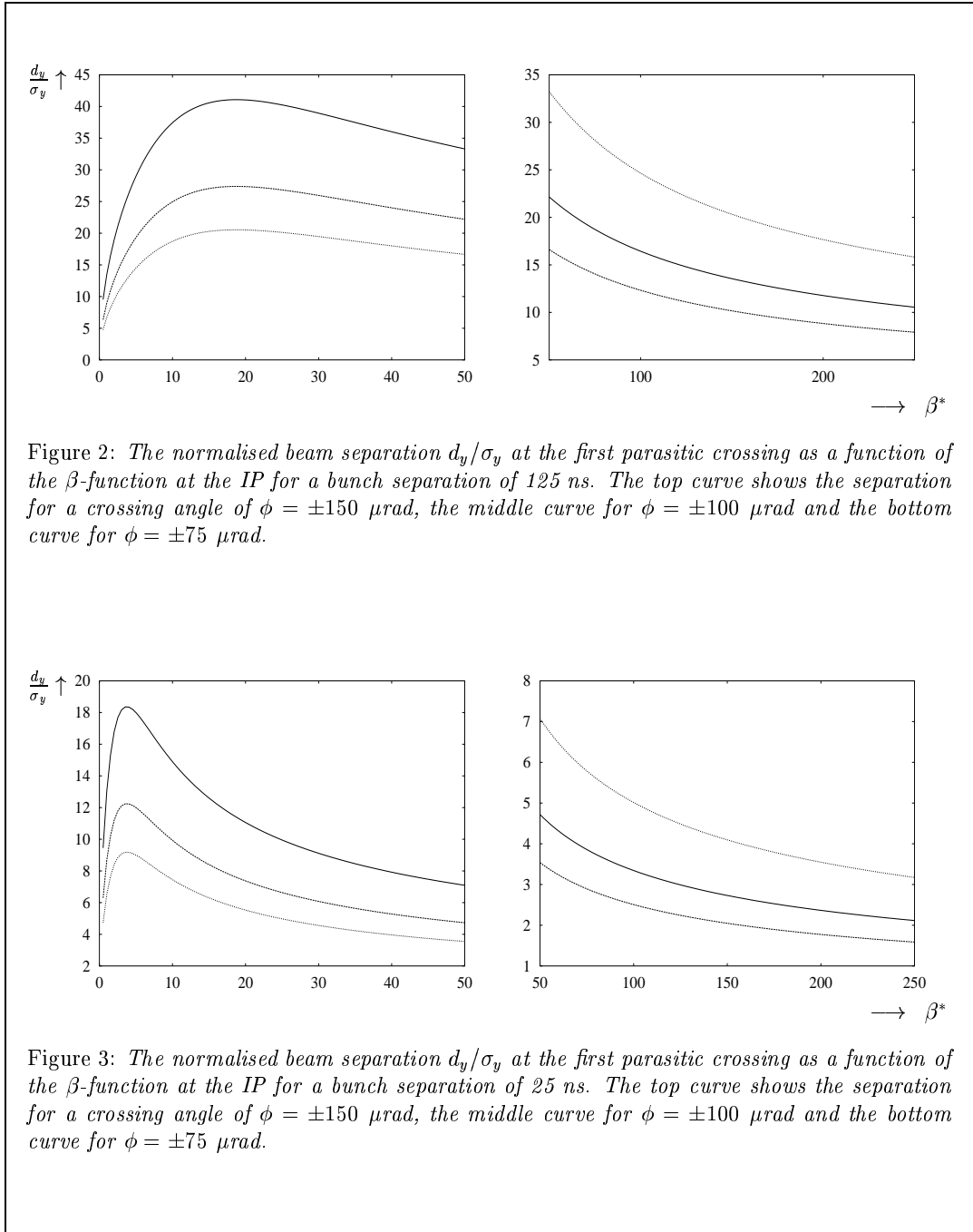

Figure 3: LHCb separation.

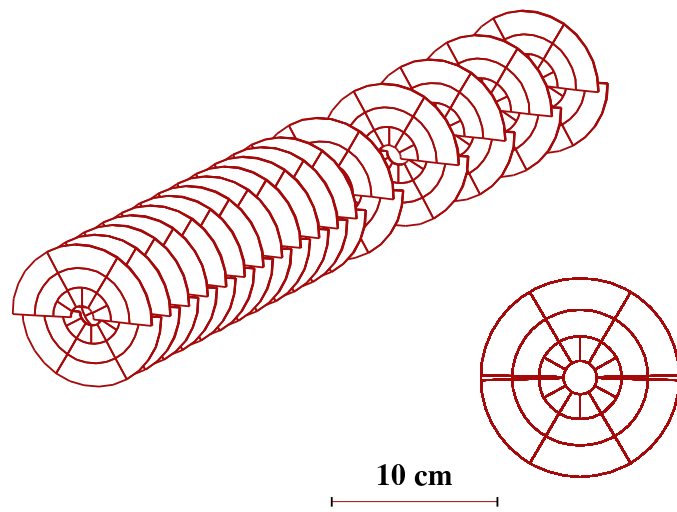
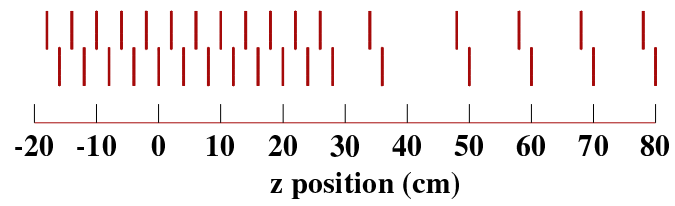

Figure 4: Layout of the LHCb Vertex Detector [3], showing the 17 stations each consisting of two staggered silicon discs.

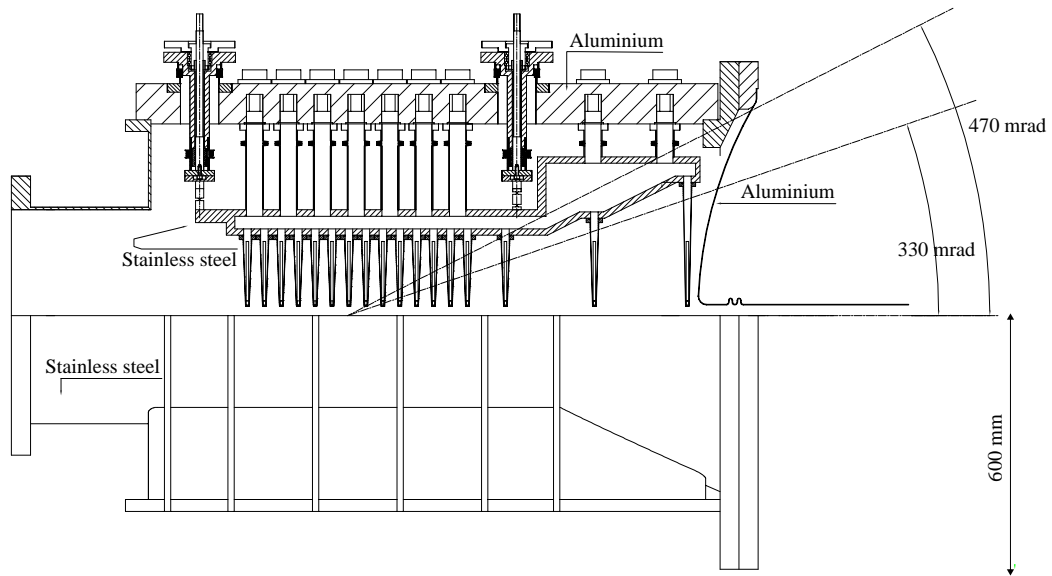

Figure 5: Side view of the vacuum tank and support structures for the LHCb Vertex Detector [3], with its 17 stations. The bottom half has been omitted for clarity.